

MotorGuide REPAIR PARTS

Models: 

GWB75V

GWT75V

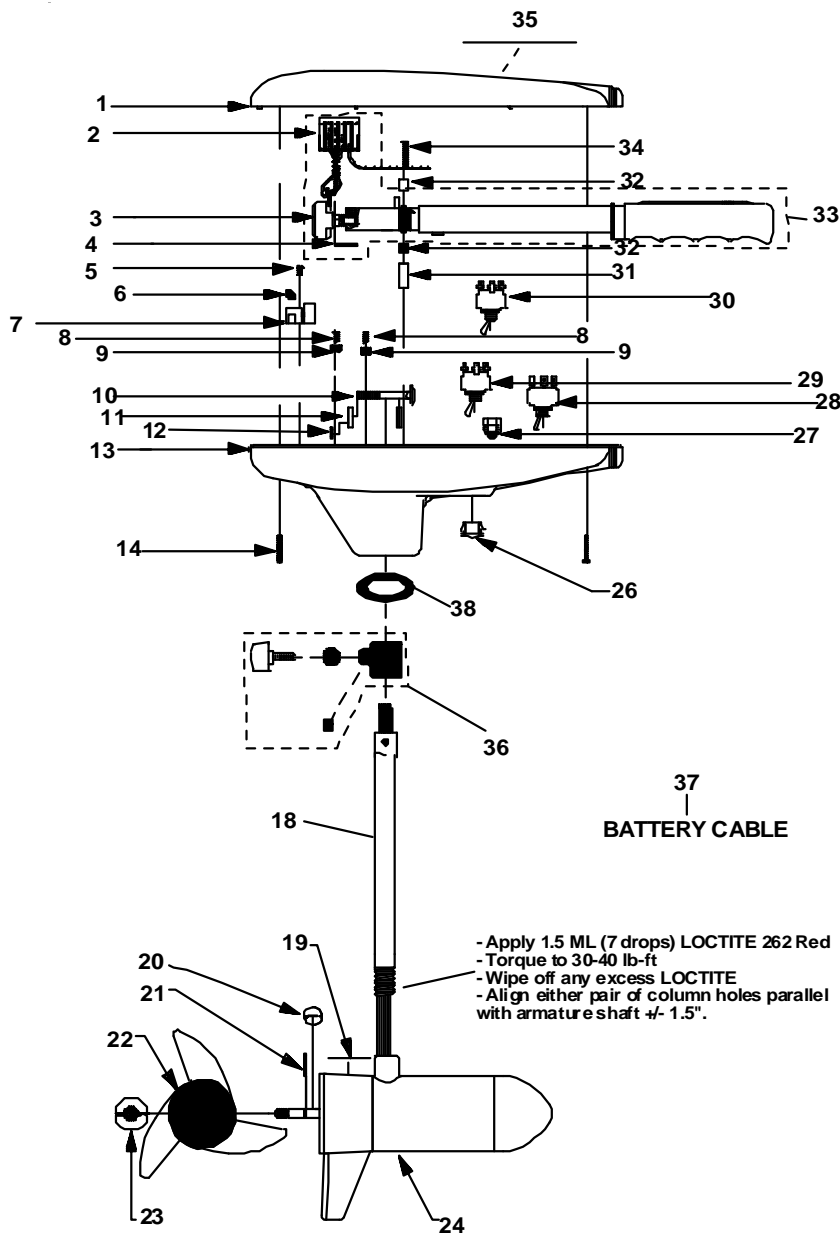

SPECIFICATIONS:

Year of Intro	1998
Thrust	75LBS
Volts	24/36VDC
Amp Draw	0 to 29 amps
Mount	20 Bow 09 Transom
Speeds	Variable

QUICK REFERENCE PARTS GUIDE:

Voltage Switch	TM153-02
DA Board	AF157-01
MOSFET	JF096-08
Motor Seal Kit	6220

PARTS ORDERING & TECH ASSISTANCE

MotorGuide Consumer Relations
 Phone 918-831-6989
 Fax 800-982-8093

Send Returned Goods to:

MotorGuide
 605 Hwy 12 West
 Starkville, MS 39760

Returned Goods must be accompanied with a Returned Goods Authorization. Contact MotorGuide Consumer Relations to obtain RGA.

KEY	DESCRIPTION	PART #	KEY	DESCRIPTION	PART #
1	TOP HOUSING COVER	XT053-35	25	DEPTH ADJUSTMENT COLLAR	AR051-02
2	AMP CONNECTOR	AP029-01	26	HOLE PLUG	FP021-03
3	POTENTIOMETER	AP168-02	27	GROMMET	GR019-03
4	POT BRACKET	AT155-03	28	TOGGLE SWITCH 3 POSITIONS	XT153-02
5	SELF TAPPING SCREW	XT141-01	29		
6	INSULATING SLEEVE	AT080-01	30	TOGGLE SWITCH 2 POSITIONS	TM153-02
7	DURA AMP BOARD	AF157-01	31	WIRE BRACKET	AT155-04
8	#10 X 1/2" SCREW	RT133-01	32	RETAINER CLAMP	AR036-01
9	TERMINAL BLOCK	FT160-03	33	HANDLE ASY	AT372-03
10	BOLT	TT134-02	34	8 X 1-3/8 SCREW	AR133-01
11	CURVED WASHER	TT171-08	35	NOMENCLATURE GWB75	XT056-31
12	NYLON LOCK NUT	XT098-01		NOMENCLATURE GWT75	XT056-32
13	T/H BASE	AR004-13	36	DEPTH COLLAR ASY	XT158-01
14	SCREW #8 X 1"	XF141-04	37	BATTERY CABLE	XT328-02
15	BAR KNOB DEPTH ADJUSTMENT	RT082-02			
16	COLUMN CLAMP WASHER	RT171-02			
17	COLUMN SUPPORT NUT	AR098-01			
18	COLUMN 36"	FR049-11			
	COLUMN 42"	FR049-15			
	COLUMN 50"	FR049-13			
19	LOWER UNIT DECAL	XT060-04			
20	MONOFILAMENT WASHER	AR175-01			
21	PROP DRIVE PIN	BR102-01			
22	PROP2 BLADE	AF124-07			
23	PROP NUT	AR099-01			
24	H/O MOTOR	AF397-16			

LOWER UNIT BREAKDOWN

Models:
GWB75V
GWT75V

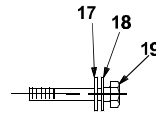
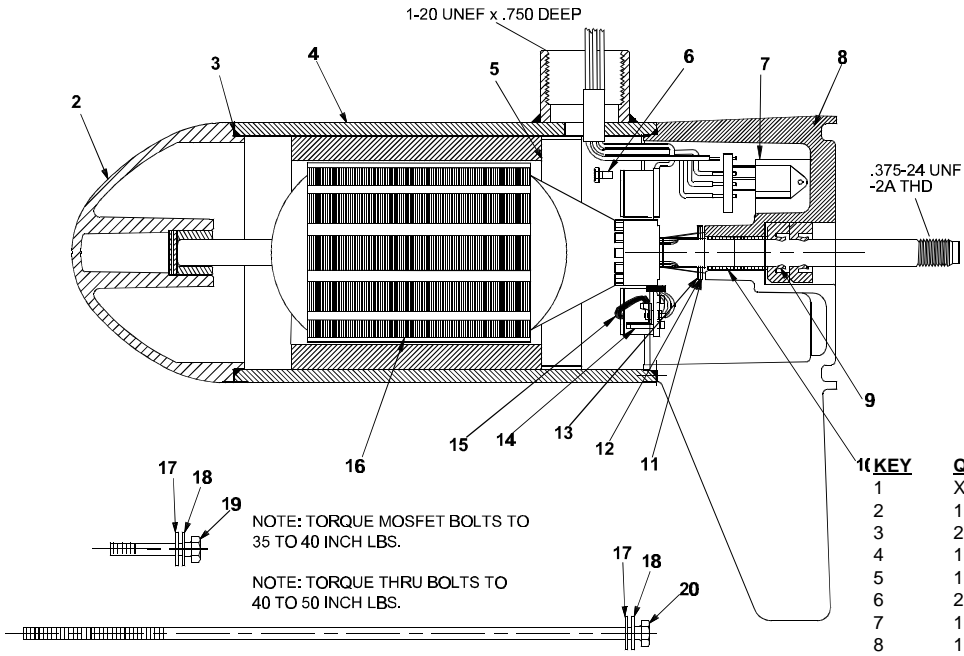

NOTE: TORQUE MOSFET BOLTS TO 35 TO 40 INCH LBS.
 NOTE: TORQUE THRU BOLTS TO 40 TO 50 INCH LBS.

DIRECTION OF ROTATION IS COUNTER CLOCKWISE WHEN VIEWED FROM PROPELLER END WITH RED POSITIVE & BLACK NEGATIVE.

KEY	QTY	DESCRIPTION	PART NO.
1	X	MOTOR	AF397-16
2	1	NOSE CAP	JF3212-02
3	2	O RING SEAL	MR217-01
4	1	HOUSING ASY	AF3210-07
5	1	RETAINER	JF233-04
6	2	BRUSH CARD SCREW	MR228-02
7	1	DURA AMP MODULE	JF096-08
8	1	COMM CAP	UF3205-02
9	2	SHAFT SEAL	MR223-01
10	1	BEARING	MR206-01
11	1	NYLATRON WASHER	MR226-01
12	1	WASHER	MR227-01
13	1	E RING	MR219-02
14	2	BRUSH SPRINGS	MR214-02
15	1	BRUSH ASY LESS SPRING	AF3201-06
16	1	ARMATURE 3.5"	AF3207-03
17	4	STATIC SEAL	MR222-01
18	4	THRU BOLT WASHER	MR216-02
19	2	DURA AMP SCREW	MR229-02
20	2	THRU BOLT	MR218-11

WIRING

36V/24V D.A. GW. WIRING DIAGRAM

SUBJECT TO DAMAGE BY STATIC ELECTRICITY ASSEMBLE AT STATIC FREE WORK STATION.

